

Ascend

MAX 2012 & 2024

**You need a WAN access solution
equipped for today and for the future.
Introducing the MAX 2012 and 2024—
scalable WAN access switches
designed with your business in mind.**



Remote Access ▾ Telecommuting ▾ Internet Access

The MAX™ 2012 and 2024 multiprotocol WAN access switches offer businesses the robust hardware, bundled Remote Networking Software and integrated firewall security needed for all mission-critical operations. The low-entry cost, scalable architecture and vast array of features make both products ideal for expanding remote networking capabilities as business needs change. Network administrators can start out with a MAX 2012 and then increase capacity and add functionality via simple software updates, reducing lifetime operation and maintenance costs.

Companies can grow their business slowly or rapidly, depending on their needs. The MAX 2012 and 2024 let them provide small office workers, mobile users and telecommuters with secure file transfer capabilities, corporate remote access and Internet access. Network administrators manage these connections through their choice of interface, either locally or remotely, with an easy-to-use Java-based configurator. The MAX 2012 and 2024 are the most cost-effective, feature-rich platforms for handling remote access needs today and far into the future.

Networking Solutions for Corporations

High-speed Series56 Digital Modems enhance call performance and reduce operating costs

Integrated high-speed Series56™ Digital Modems provide full access to analog callers that dial into the MAX over digital access lines such as channelized T1 or PRI. The MAX 2012 and 2024 use these modems to ensure reliability and eliminate the noise, downtime and operating costs that can be present with stand-alone analog modem technology.

- ▶ 12-port Series56 Digital Modem modules
- ▶ Support for data modem modes: K56flex, V.34, V.32bis, V.22bis, V.22 and below
- ▶ Support for error correction and data compression: V.42 LAPM, MNP2-4, MNP 10 error correction; V.42bis and MNP5 data compression
- ▶ MNP 10EC enhanced cellular performance

Routing, bridging and terminal server functions ensure network interoperability

Integrated support for industry-standard routing and bridging functions enables users to connect to a variety of resources within corporate networks. These protocols complement the Remote Networking Software package which includes support for IPX and AppleTalk routing. The proven technology in routing and terminal server protocols permits corporations to extend their network to offer a broad range of services to users.

- ▶ Remote Networking Software package supports IPX and AppleTalk routing
- ▶ TCP/IP with RIP2 and OSPF routing protocols
- ▶ Bridging all protocols (BCP standard bridging)
- ▶ PPP, SLIP and C-SLIP terminal service
- ▶ Telnet, ARA
- ▶ Dynamic IP address assignment
- ▶ V.120 asynchronous rate adaption

Comprehensive security for iron-clad remote networking

Support for standard user-authentication systems fits into your current network security architecture. Networked, server-based authentication makes it easy to manage large-scale remote access applications from a central site. Extended RADIUS functionality allows service providers and network managers to integrate the accounting, authentication and authorization capabilities needed to manage their remote network.

- ▶ PAP, CHAP, and MS CHAP
- ▶ Ascend Access Control (extended RADIUS), RADIUS, TACACS and TACACS+
- ▶ Encrypted token-card security
- ▶ Callback (digital connections), Calling Line ID (CLID)
- ▶ Password protected terminal server access
- ▶ Transmit and receive packet filtering
- ▶ Secure Access™ Firewall (included)

Point-and-click Java configurator provides end-to-end network control

A Java-based configuration utility helps network administrators to get users up and running in less than 15 minutes. This utility guides them through the applications and features complete HTML-based on-line help. Network administrators can manage all functions of the MAX 2012 and 2024 through their choice of interface, either locally or remotely, using intuitive graphical configuration software.

- ▶ Java-based configurator for point and click management
- ▶ SNMP MIBs
- ▶ Password protected Telnet remote management
- ▶ Local management via VT-100 terminal
- ▶ PPP Link Quality Monitoring (LQM)
- ▶ Annex D Frame Relay link monitoring
- ▶ FLASH memory for easy software download
- ▶ ISDN event log and Syslog support

Corporate Remote Access

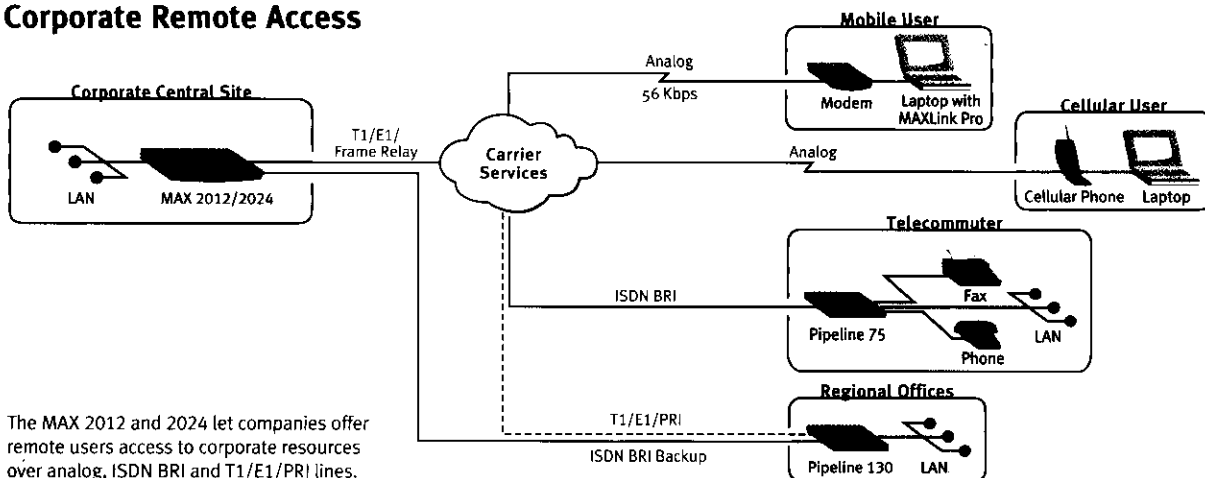

The MAX 2012 and 2024 let companies offer remote users access to corporate resources over analog, ISDN BRI and T1/E1/PRI lines.

Software Enhancement capabilities protect investment costs

The MAX 2012 and 2024 offer a scalable platform that lets network administrators add functionality without incurring additional expense. Software enhancements and MAX Stack capabilities allow them to integrate users and additional MAX units seamlessly into their network.

- ▶ Software-upgradable Series56™ Digital Modem modules for adding support for more analog and cellular callers
- ▶ Enhancements such as ISDN PRI signaling and Hybrid Access™ 2000 for additional functionality (ISDN PRI signaling, HDLC processing, Frame Relay support)
- ▶ MAX Stack aggregates multiple MAX systems by allowing them to act as a single WAN access switch

Consolidation drives down the total cost of ownership

By eliminating the need for separate modem banks, terminal servers and routers, the MAX saves network equipment and transmission costs. With Hybrid Access, the MAX 2012 and 2024 consolidate a dynamic mix of access lines over high-speed digital trunks for up to 24 simultaneous connections.

- ▶ ISDN PRI
- ▶ T1/E1 with integrated CSU
- ▶ MAX 2012 supports a single 12-port module while the MAX 2024 supports two 12-port modules

Bandwidth on demand maximizes performance and decreases costs

Dial-up connections are automatically set up and torn down for transparent client-server computing across the WAN. Dynamic Bandwidth Allocation™ aggregates multiple calls for greater bandwidth and lower costs.

- ▶ Dial-on-demand bandwidth based on packet address
- ▶ Increase or decrease bandwidth dynamically during an active session
- ▶ 56 Kbps to 1.54 Mbps selectable bandwidth per call
- ▶ Bandwidth is controlled manually, automatically, or by time-of-day profile
- ▶ Supports inverse multiplexing protocols (MP, MP+,BACP)
- ▶ Industry-standard STAC compression
- ▶ RFC 1144 TCP header compression

Flexible platform allows seamless connections to backbone services over a variety of interfaces

The MAX 2012 and 2024 provide users with options for connecting into a local or remote backbone network. Users can connect to switches or to backbone routers over any of the following transport options:

- ▶ Ethernet (AUI or 10Base-T) for connecting to the backbone network at up to 10 Mbps
- ▶ Frame Relay over a V.35 serial port for high-speed connections at up to 8 Mbps
- ▶ T1/E1/PRI ports with integral CSU for making remote connections to the backbone network

Corporate Telecommuting and Internet Access

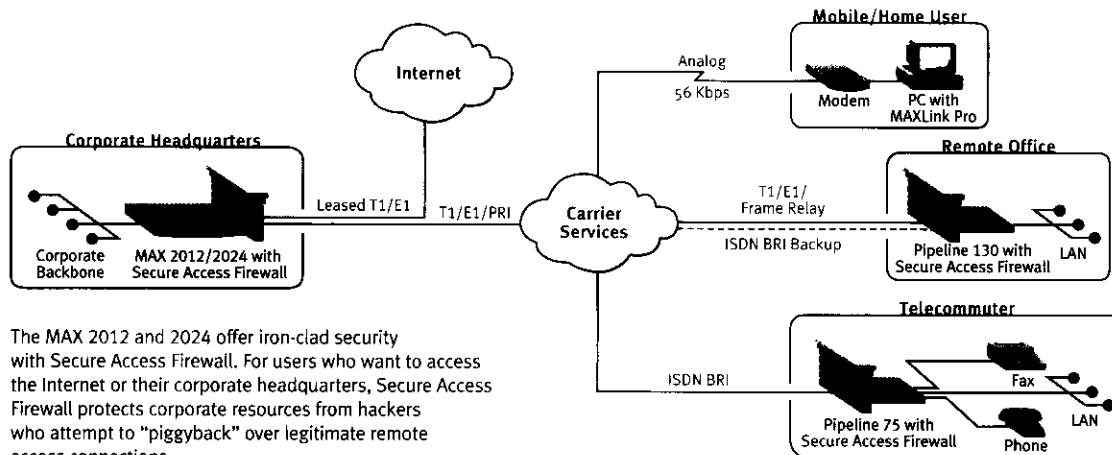

The MAX 2012 and 2024 offer iron-clad security with Secure Access Firewall. For users who want to access the Internet or their corporate headquarters, Secure Access Firewall protects corporate resources from hackers who attempt to "piggyback" over legitimate remote access connections.

Remote Networking Software

Every MAX 2012 and 2024 includes a comprehensive Remote Networking Software package. This software offers companies a premier value as it includes everything small- to mid-sized businesses need to cost-effectively get remote users, telecommuters, mobile users and LAN users up and running in a matter of minutes. This offering includes:

- ▶ Multiprotocol Call Routing
- ▶ MAXLink Pro™
- ▶ MAXDial™

Multiprotocol Call Routing

The MAX 2012 and 2024 remote networking software includes IPX and AppleTalk protocol support so that network administrators can extend their network to offer a broad range of applications to their users. This optimized solution links network users in remote or branch offices to corporate backbones for server access. Users can send e-mail, share data between servers and access remote databases. It also supports IPX spoofing and AppleTalk ARA.

MAXLink Pro

MaxLink Pro is available free with either a MAX 2012 or a MAX 2024. This client software combines protocol stack software with an award-winning suite of applications to provide simultaneous access to both IP and IPX network services. It is an easy and economical way to add remote users to a growing network. Once connected, users become full-fledged nodes on the LAN with access to file servers, printers, the Internet and electronic mail. Both Windows and Macintosh users alike can access the corporate network from anywhere—whether they are traveling, telecommuting or working at a remote site.

MAXDial

Users on the corporate LAN can access the outside world using MAXDial software and the MAX 2012 and 2024. MAXDial eliminates the need to install a direct line and a desktop modem in every office by providing the same functionality, without the added expense. It lets users dial out or send out faxes via the modem cards in the MAX 2012 and 2024. MAXDial runs under Windows 3.1x and Windows 95 and supports the AT command set for V.34 and all other modem modes .

MAX 2012 & 2024

Protecting corporate resources with Secure Access Firewall

Ascend's Secure Access™ Firewall is available on the MAX 2012 and 2024 and uses state-of-the-art firewall technology and delivers a comprehensive, fully integrated security solution for corporate networks. Secure Access Firewall allows carriers and ISPs to offer secure services to their customers. It protects your company's information assets at the corporate LAN, remote offices and telecommuters' home offices.

It also integrates the standard security features that are offered on your Ascend remote networking system with comprehensive security features such as transparency, dynamic firewall, and monitoring and logging.

Secure Access Firewall provides a cost-effective single vendor solution for securing your company's remote network against attacks on sensitive data. (See the Secure Access Firewall datasheet or visit our web site for more information).

Software Enhancements

The MAX 2012 and 2024 protect investment costs with a scalable platform that customers can use to expand their capabilities as their remote network needs change. Small businesses and organizations who have limited needs can get a MAX 2012 and be assured that they have a system that will satisfy their requirements for years to come. As their business grows and requirements change, they can grow their network and add functionality via a simple software update.

ISDN PRI Software

Option ISDN signaling software supports incoming ISDN signaling from Ascend's Pipeline®, MAX products or other ISDN access devices. The ISDN signaling supports ISDN connections for analog modem and digital services dial-in traffic.

- ▶ PRI with integrated CSU
- ▶ PRI to T1 signaling conversion
- ▶ D4 to ESF conversion
- ▶ D-channel multiplexing
- ▶ Frame Relay over ISDN B-channels
- ▶ X.25 over ISDN B-channels
- ▶ D-channel X.25 packet services
- ▶ Calling Line Identification (CLID)
- ▶ Signaling homologation in over 30 countries worldwide

Hybrid Access 2000

Hybrid Access™ 2000 provides integrated digital sessions via a T1/E1 or ISDN PRI interface. It gives users integrated remote access for ISDN and Frame Relay, and supports other networking devices that use ISDN and Frame Relay. Hybrid Access 2000 includes ISDN PRI signaling, HDLC processing and Frame Relay support.

Digital Modem Upgrade

As the corporate network grows, companies using a MAX 2012 can decide to upgrade to a MAX 2024 by adding an additional 12-port modem module. This provides support for up to 24 concurrent sessions. Ascend's Series56 Digital Modems are software upgradable, allowing network administrators to add functionality without swapping out hardware.

MAX Stack

MAX Stack increases the scalability of the MAX 2012 and 2024 and lets network administrators fully utilize their existing resources to better manage the bandwidth on their network. A MAX Stack allows several MAX units to operate as a single, more powerful solution that facilitates the negotiation of Bandwidth Allocation Control Protocol (BACP), Multilink PPP (MP) or Multilink Protocol Plus™ (MP+) calls across the T1/E1/PRI lines. If the request for additional channels is made and the MAX that originally handled the call has no available channels, additional channels can be allocated from other MAX units in the stack.

It can also be used in situations where a network manager has assigned a single hunt group to all the T1/E1/PRI lines on the MAX Stack, allowing calls to be routed to multiple destinations from one phone number.

Hardware Specifications

Dimensions	1.75 in x 17 in x 12 in [4.5 cm x 43.2 cm x 30.5 cm]
Weight	10 lbs [4.6 kg]
LAN Interface	Ethernet 10Base-T via RJ-45 jack, Ethernet AUI via DB-15 Connector
WAN Interfaces	1 T1/E1/PRI with integrated CSU 1 FT1/T1 for leased line services Serial port (V.35)
Software Upgrade	Via built-in flash RAM, remote downloadable
Power Requirements	80 Watts, 47-63 Hz, 90-240 VAC, 270 BTU/hour
Operating Requirements	Temperature: 32-104°F [0-40°C] Altitude: 0-14,800 feet [0-4,500 meters] Relative Humidity: 5-90% (non-condensing)
Safety Certifications	CSA 950, NTRL/UL 1950, TUV EN 60 950
EMI/RF	FCC Part 68, FCC Part 15, E55022, EN50082-1

Key Features

LAN Protocols	IP, IPX, AppleTalk
Routing Protocols	BCP Bridging, RIP, RIP2, OSPF (IP only), IGMP Multicast forwarding
WAN Protocols	PPP, ARAP, SLIP, C-SLIP, Async PPP, Sync PPP, HDLC, ARA, Async IPX, X.25, PAD, X.25 over B-channel, V.120, D4 framing (T1/E1), G703/732 framing (R1), Frame Relay PVC, Hybrid Access, PPP-FR gateway, FR NNI, ISDN signaling
Modem	K56flex, upgradable to ITU-T 56 Kbps, V.34, V.32bis, V.32, V.22bis, V.22A/B, V.23, V.21, Bell 212A and 103, MNP 10-EC, MNP, fax modem send up to 14.4
Remote Networking Software	Multiprotocol call routing adds IPX and Async IPX with local spoofing, AppleTalk and AppleTalk Remote Access 1.0 and 2.0 MAXDial MAXLink Pro
Bandwidth Management	MultiLink PPP (MP), MultiLink Protocol Plus (MP+), Bandwidth Allocation Control Protocol (BACP), TCP header compression, data compression (Ascend/Microsoft/STAC V9), AppleTalk Remote Access, compatible with ARA 1.0 and 2.0
Security	Secure Access Firewall, Ascend Access Control (extended RADIUS), RADIUS, TACACS, TACACS+, Password Authentication Protocol (PAP), Challenge Authentication Protocol (CHAP), MS-CHAP, token card, Calling Line ID (CLID), packet filtering, SNMP, console management (VT-100), PPP callback, user authentication
Management	Java Configurator, Console management software (runs on Windows 95 and Windows 3.x), Telnet, NASI, SNMP MIB-2, PPP LQM, Frame Relay Annex D, Frame Relay ITU Annex A, Frame Relay ANSI Annex D

MAX 2012 and 2024 Back Panel

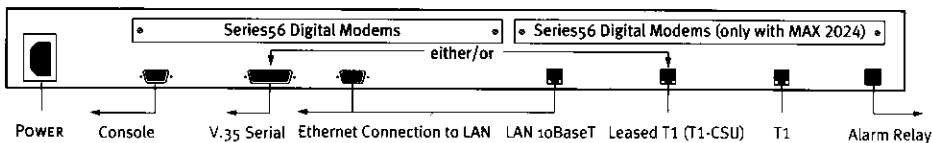

Ascend's Series56
Digital Modems are based on
K56flex technology.

Ascend Communications, Inc.

Worldwide and North American Headquarters
One Ascend Plaza
1701 Harbor Bay Parkway
Alameda, CA 94502, United States
Tel: 510.769.6001
Fax: 510.747.2300
E-mail: info@ascend.com
Toll Free: 800.621.9578
Fax Server: 415.688.4343
Web Site: <http://www.ascend.com>

European Headquarters
Rosemount House
Rosemount Avenue, West Byfleet
Surrey KT14 6NP, United Kingdom
Tel: +44 (0) 1932.350.115
Fax: +44 (0) 1932.350.199

Japan Headquarters
Level 19 Shinjuku Daiichi-Seimei Bldg.
2-7-1 Nishi-Shinjuku
Shinjuku-ku, Tokyo 163-07, Japan
Tel: +81.3.5325.7397
Fax: +81.3.5325.7399
Web Site: <http://www.ascend.co.jp>

Asia-Pacific Headquarters
Suite 1419, Central Building
1 Pedder Street
Central, Hong Kong
Tel: +852.2844.7600
Fax: +852.2810.0298

Latin, South America and the Caribbean Headquarters
One Ascend Plaza
1701 Harbor Bay Parkway
Alameda, CA 94502, United States
Tel: 510.769.6001
Fax: 510.747.2669

Ascend Communications, Inc. is a leading, worldwide provider of remote networking solutions for corporate central sites, Internet Service Providers' points of presence, remote offices, mobile workers, and telecommuters. Ascend develops, manufactures, markets, sells and supports products which utilize bandwidth on demand to extend existing corporate networks for applications such as remote LAN access, Internet access, telecommuting, SOHO connectivity and video-conferencing/multimedia access. Detailed information on Ascend products, news announcements, seminars, service and support is available on Ascend's home page at the World Wide Web site: <http://www.ascend.com>.

Ascend markets the GRF, MAX, Multiband, MultiDSL, Pipeline, NetWarp and Security families of products. Ascend products are available in more than 30 countries worldwide.

Ascend and the Ascend logo are registered trademarks and all Ascend product names are trademarks of Ascend Communications, Inc. Other brand and product names are trademarks of their respective holders.

Specifications are subject to change without notice.

© Copyright 1997 Ascend Communications, Inc.

01-49

4-97



**Remote Networking
Solutions That Work.™**

